

SPECIFICATION PRINT

Bronze Ball Check Valve

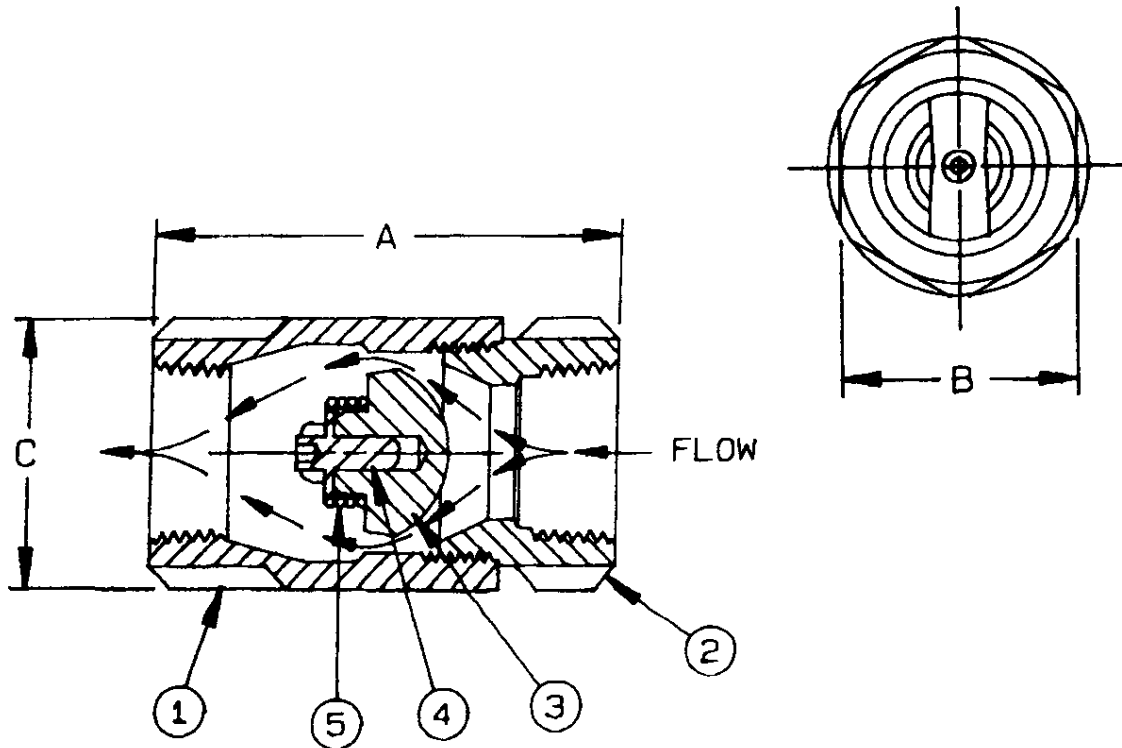

FEATURES:

- Bronze Body
- RTFE Ball Check
- Patented and reliable protection against reverse flow
- Spring loaded for fast seating action
- Center guided so radial alignment is not needed
- Straight-through flow minimized velocity change
- Broad range of applications, including 125 PSIG saturated steam.

MATERIAL SPECIFICATIONS:

- Rated 400 PSIG WOG, cold non-shock
- Body (1): Bronze - ASTM B584, UNS Alloy C84400
- Retainer (2): Brass - ASTM B16 (1/4"-1)
- Bronze - ASTM B584, UNS Alloy C84400 (1-1/4"-3")
- Ball Check (3): RTFE Reinforced Teflon™
- Guide (4): Brass - ASTM B16
- Spring (5): Steel - AISI 316 Stainless Steel
- NPT Threaded 1/4"-3"

DIMENSIONAL SPECIFICATIONS:

Size	A	B	C	Wt/100
1/2"	2.31	1.12	1.12	38
3/4"	2.87	1.37	1.5	75
1"	3.5	1.75	1.93	145
1-1/4"	4.18	2.12	2.37	275
1-1/2"	4.93	2.5	2.81	394
2"	6	3	3.68	630
2-1/2"	7	3.5	4.5	1400
3"	8.12	4.12	5.31	1665



Penn Separator Corp.

PO Box 340, Brookville, PA 15825

Bronze Check Valve

ARS 6/20/07

A 26168-1