

SPECIFICATION PRINT

Blowdown Separator

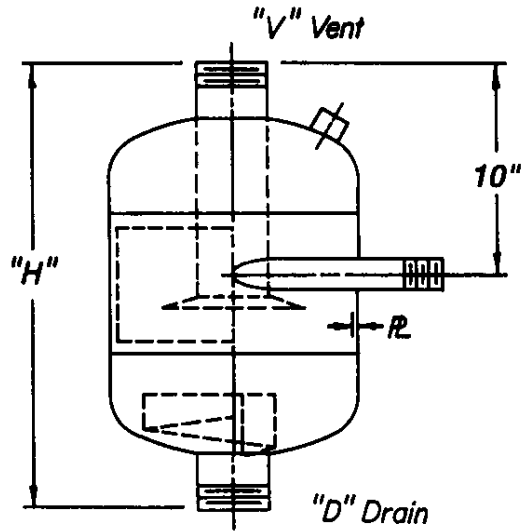
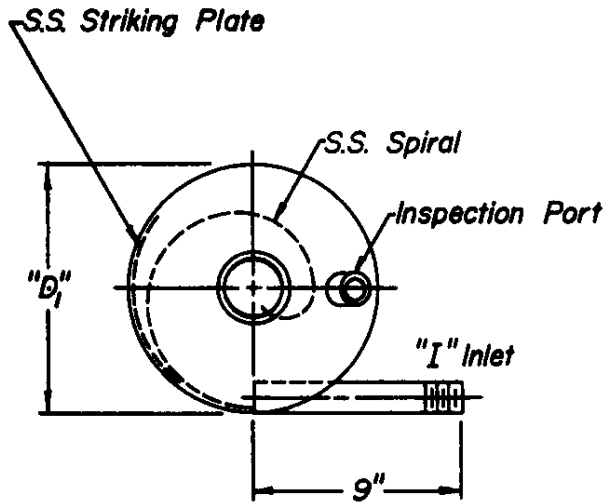

Model No. A-14-_____

H	D ₁	I	D	V	R
21	10	1	2	2-1/2	

Constructed and stamped in accordance with the latest ASME Code, Sec. VIII, Div. 1, with stamp MAWP is 250 PSIG @ 450° F.

MATERIAL SPECIFICATIONS

Heads	SA516-70
Shell	SA53-B
Nozzles	SA106-B, SA53-B
Couplings	SA105
Stk. Pl.	SA240-304
Spiral	SA240-304
Finish	Red Oxide Primer



Penn Separator Corp.

PO Box 340, Brookville, PA 15825

Blowdown Separator

Rev. 2 07/18/12 MJG

A16008-5