

SPECIFICATION PRINT—Flanged T-Type Inline Separator

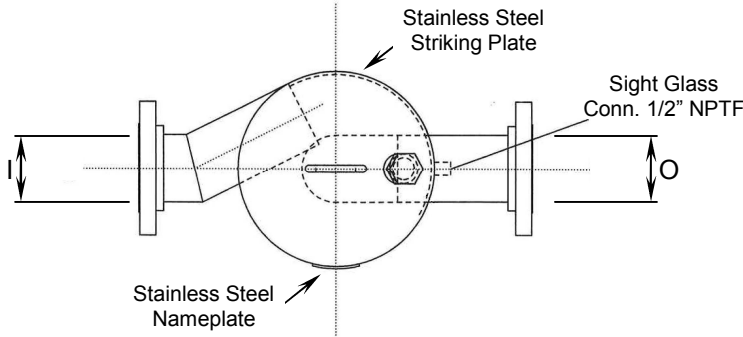

MATERIAL SPECIFICATIONS:

Heads: SA516-70 or SA234WPB
 Shell: SA53-B, or SA516-70
 Pipe: SA53-B, or SA106-B
 Coupling: SA105
 Flanges: SA105
 Finish: Shop Primer

DIMENSIONS

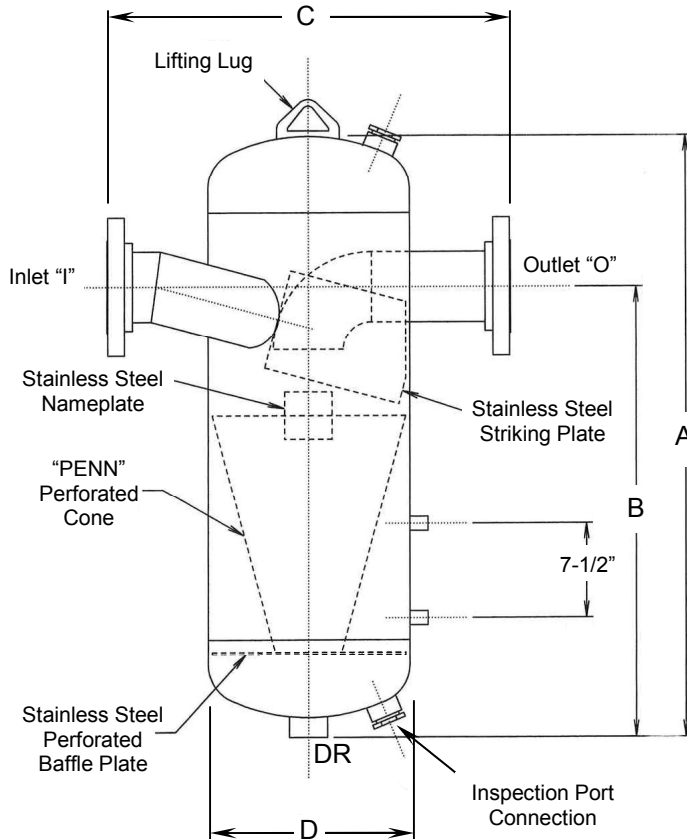

MODEL NO.	A	B	C	D	I	O	DR
IS .75-3	11"	7.5"	12"	3.5"	.75"	.75"	.75"
IS 1-4	15"	10"	14"	4.5"	1"	1"	.75"
IS 1.25-5	17.5"	12.5"	15"	5.5"	1.25"	1.25"	.75"
IS 1.5-6	21.25"	15"	15"	6.5"	1.5"	1.5"	.75"
IS 2-6	21.25"	15"	18"	6.5"	2"	2"	1"
IS 2.5-8	28"	20"	20"	8.5"	2.5"	2.5"	1"
IS 3-10	32.75"	24"	21"	10.5"	3"	3"	2"
IS 4-12	38.75"	29"	25"	12.75"	4"	4"	2"
IS 5-16	46.125"	34.875"	32"	16"	5"	5"	2"
IS 6-18	50"	37.75"	34"	18"	6"	5"	2"
IS 8-24	65.625"	51"	46"	24"	8"	6"	2"
IS 10-30	83.5"	63.5"	50"	30"	10"	8"	3"
IS 12-36	98"	76.5"	66"	36"	12"	10"	3"
IS 14-42	117"	89"	74"	42"	14"	12"	3"
IS 16-48	135"	102"	78"	48"	16"	14"	3"
ISO 6-18	50"	37.75"	34"	18"	6"	6"	2"
ISO 8-24	65.625"	51"	46"	24"	8"	8"	2"
ISO 10-30	83.5"	63.75"	50"	30"	10"	10"	3"
ISO 12-36	97.5"	76.5"	66"	36"	12"	12"	3"
ISO 14-42	117"	89"	74"	42"	14"	14"	3"

NOTES:

Standard Pressure Ratings:

150 psig at 450°F—150 psig ANSI Flanges

250 psig at 450°F—300 psig ANSI Flanges

* Other pressure and temperature ratings available upon request.

- IS Models with 6" thru 16" inlets have outlets one pipe size smaller.
- Lifting lugs supplied on Inline Separators with 5" inlets or larger.
- Sight glass connections supplied on Inline Separators with 3" inlets or larger.
- Constructed and stamped in accordance with the latest ASME Code, Sec. VIII, Div. 1, with stamp.



Penn Separator Corp.

PO Box 340, Brookville, PA 15825

Flanged T-Type Inline Separator

Rev. 03/04/13 MJG

A 46002-3