

SPECIFICATION PRINT - Up/Down Inline Separator

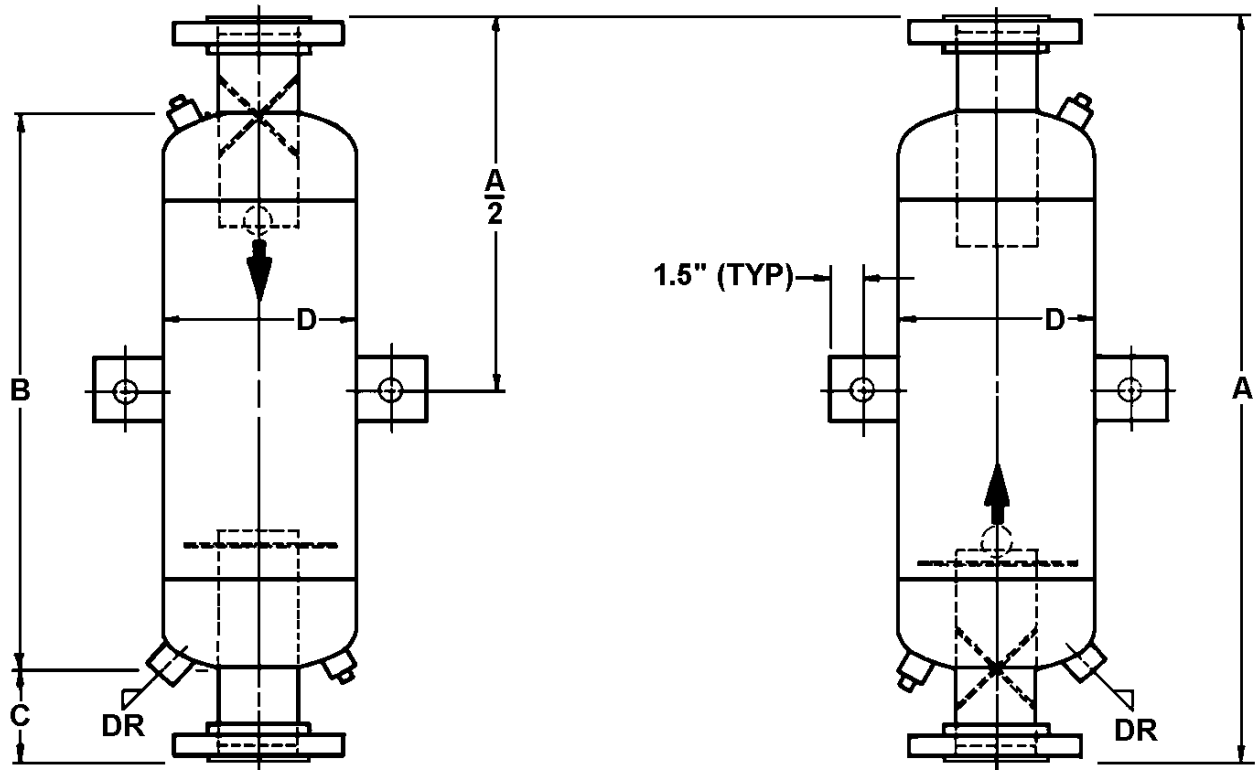

Down-Thru Model "ISD"

Up-Thru Model "ISU"

Dimensions are in Inches

MODEL ISD/ ISU:	SIZE	A	B	C	D	DRAIN
2-6	2	32	24-1/2	3-3/4	6-5/8	3/4
2 1/2-8	2-1/4	32	24-1/2	3-3/4	8-5/8	3/4
3-8	3	32	24-1/2	3-3/4	8-5/8	1
4-10	4	36	28	4	10-3/4	1-1/2
5-12	5	38	30	4	12-3/4	2
6-12	6	40	32	4	12-3/4	2
8-16	8	48	40	4	16	2
10-20	10	60	48	6	20	2
12-24	12	74	60	6	24	3
14-30	14	90	78	6	30	3
16-30	16	100	88	6	30	3
18-36	18	108	92	8	36	3
20-36	20	120	104	8	36	3

Note: Designed and constructed to ASME Code Sec. VIII, Div. 1, with stamp. Supports provided on 8" inlet and larger units.

Material Specifications:

Heads: SA516-70, SA234WPB
 Shell: SA53-B, SA516-70
 Pipe: SA53-B, SA106-B
 Coupling: SA105
 Flanges: SA105
 Finish: Shop Primer

Standard Pressure Rating:

150 psig at 450°F.- With 150# ANSI Flanges.
 250 psig at 450°F.- With 300# ANSI Flanges

Other pressures and temperatures are available upon request.



Penn Separator Corp.

PO Box 340, Brookville, PA 15825

Up/Down Inline Separator

Rev. 4 06/22/98 SAM

ID 418-R4