

SPECIFICATION PRINT

Blowdown Separator Floor Stand

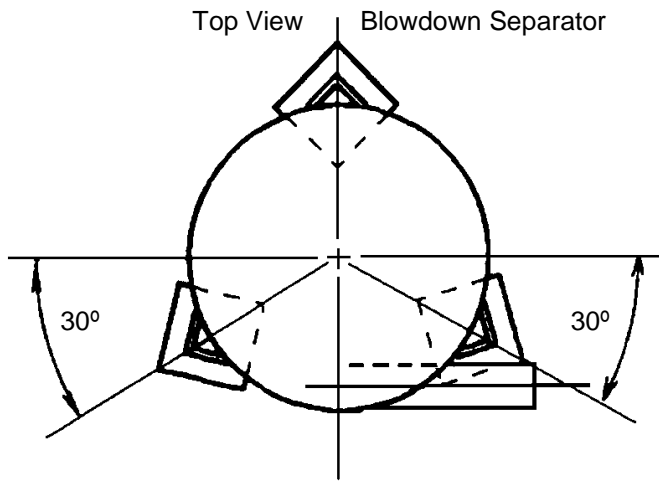

DIMENSION CHART

D	A	B
2"	22"	28"
2.5"	23"	30"
3"	24"	31"
4"	25"	32"
5"	30"	33"
6"	34"	35"

Screwed or Beveled Connections

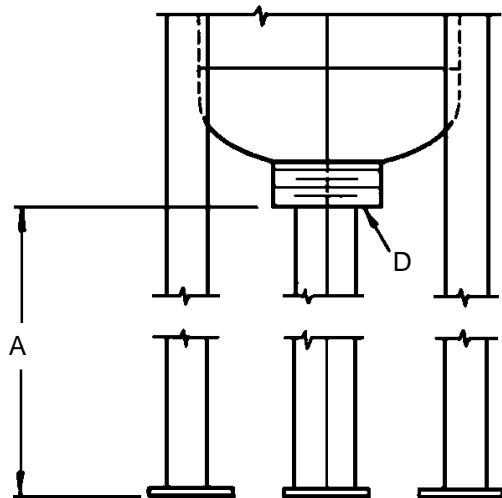

Flanged Connections

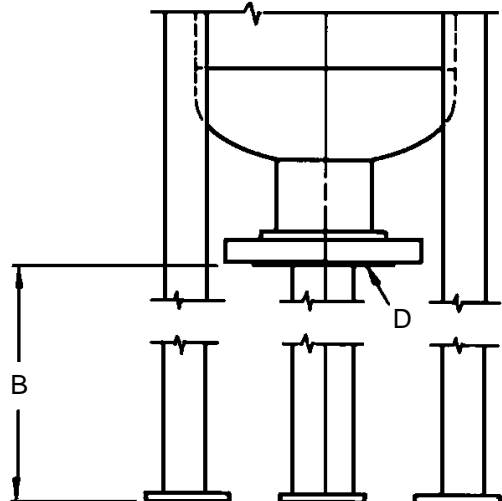

Notes:

- Blowdown Separator Floor Stand for models A-20, A-34 and A-56 are factory fabricated using 2" x 2" x 0.25" angle.
- Floor stands for A-14 models are factory fabricated using 1.5" x 1.5" x 0.25" angle.
- If an 18DF, 16DS, or 20AO Aftercooler is furnished with separator, see dimension chart above for height "A" or "B". Be sure sufficient height is available for the aftercooler and elbow, when required. (Dimensions in column A and B are determined by separator drain size, listed in column D.)
- Dimension "A" or "B" will always be 18" when a 5D drain mixer is supplied or when a separator is furnished without an aftercooler.
- Other heights available upon request.



Penn Separator Corp.

PO Box 340, Brookville, PA 15825

Blowdown Separator Floor Stand

MJG 10/30/08 Rev. 3

A 26003-2