

# SPECIFICATION PRINT

## Blowdown Separator

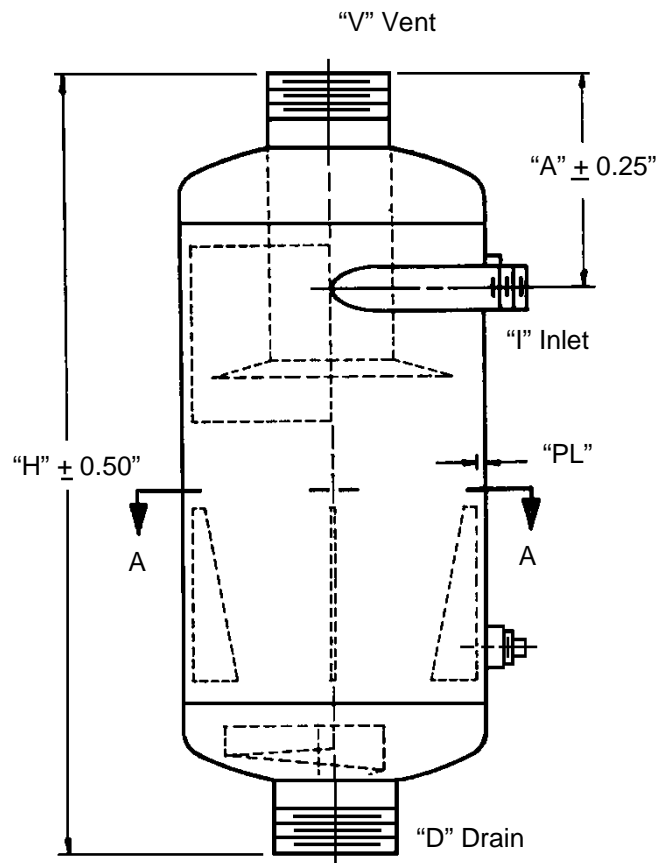
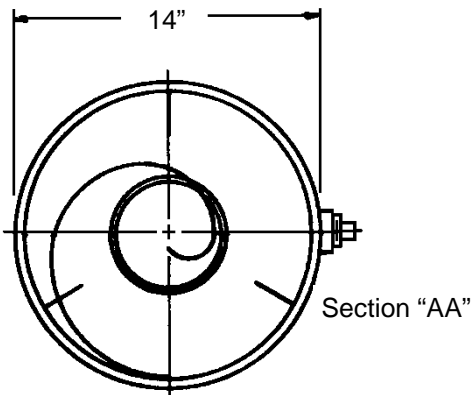
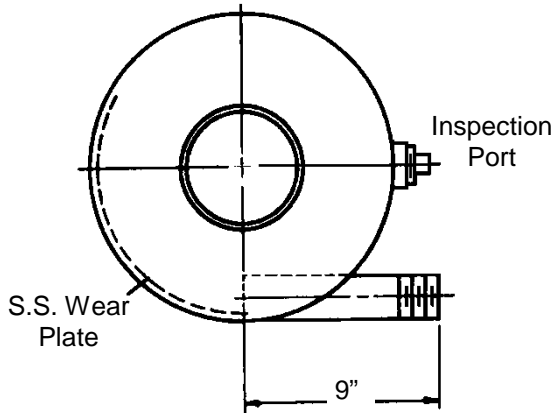

Model No. \_\_\_\_\_ MAWP 250 PSIG @ 450°F

All Pipe Sizes Shown Are Nominal.

### DIMENSIONS

H	22"	34"	56"		
I	0.75"	1"	1.25"	1.50"	2" 2.50"
D	2"	2.50"	3"	4"	5" 6"
V	2"	2.50"	3"	4"	5" 6"
PL	0.3125"	0.375"			
A	11"				

Constructed and stamped in accordance with the latest ASME Code, Sec. VIII, Div. 1, with Stamp.

### MATERIALS

Heads	SA 516-70
Shell	SA 53-B
Couplings	SA 105
Wear Plate	SA 240-304
Baffles	SA 240-304
Nozzles	SA 53-B, SA 106-B
Finish	Red Shop Primer



PO Box 340, Brookville, PA 15825

**Blowdown Separator**

Rev. 3 SAM 07-14-00

A 15186